

1

2

3

4

A

A

SALT SPRAY		
G/F	NA	
3u" 6u"	24H	
15u" 30u" 50u"	48H	

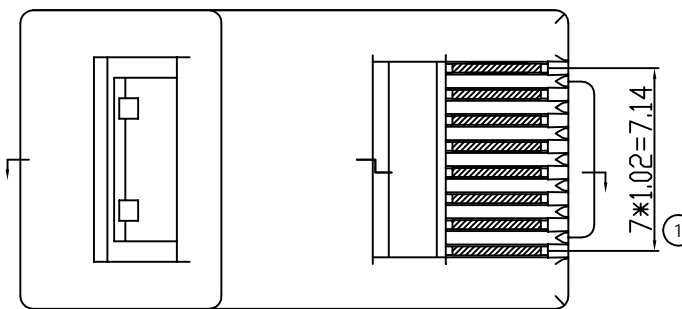

B

B

SPECIFICATION NOTES:

1.ELECTRICAL:

- 1.1 VOLTAGE RATING: 150 VAC RMS
- 1.2 CURRENT RATING: 1.5 AMP
- 1.3 CONTACT RESISTANCE: 20m MAX.
- 1.4 INSULATION RESISTANCE: 1000M MIN. AT 500V DC.
- 1.5 WITHSTAND VOLTAGE:1000V D.C. or A.C. PEAK;ONE CONTACT TO ALL OTHER CONTACTS CONNECTED TOGETHER. 1500V D.C. OR A.C. PEAK;ALL CONTACTS CONNECTED TOGETHER TO SHIELD,(HOUSING/MOUNTING PLATE) IF PRESENT. @ 0.5mA 50 Hz OR 60 Hz A MINUTE

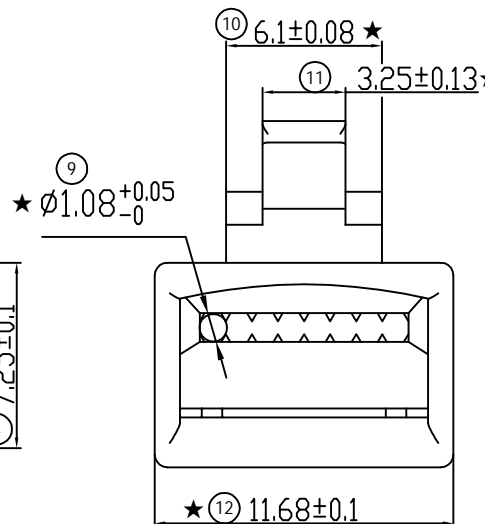
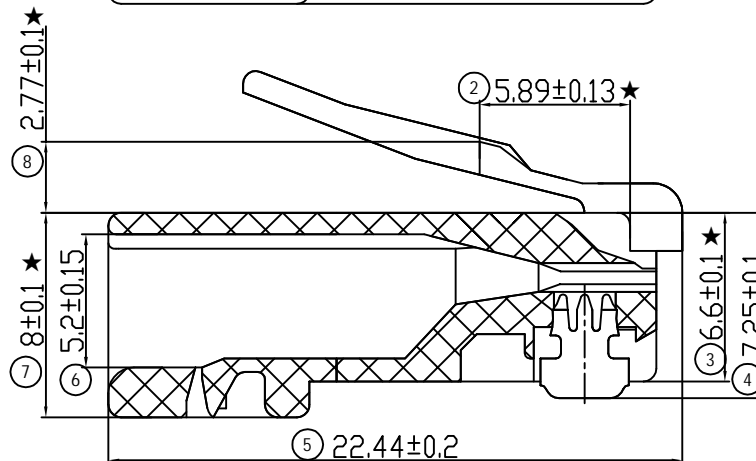

C

C

2.MECHANICAL:

- 2.1 RETENTION STRENGTH:50N MIN. FOR 60S±5S
- 2.2 OPERATING LIFE:750 CYCLES.
- 2.3 INSERTION FORCE:30N MAX.

3.ENVIRONMENTAL:

- 3.1 OPERATION: -25 ~ +55 GB 10753-89
- 3.2 STORAGE:-10 ~ +40 RELATIVE HUMIDITY<80%, GB 10753-89
- 3.3 STORAGE TIME:12 MONTHS
- 3.4 SALT SPRAY TEST:SEE TABLE

02	QWY-1029-17		铜合金 T=0.35
01	PCT140307	8P8C塑壳 超短抽芯	SEE TABLE
NO.	DWG NO.	NAME	DESCRIPTION

D

D

RoHS Compliant u"=μinch

				TOLERANCES 公差	Material: 材质	PC 普通透明环保	Designed: 设计	NAME: 名称		PL120	
				00~15 ±0.15 15~30 ±0.20 30~ ±0.25	Finish: 电镀	Au:G/F	Checked: 审核	DWG NO: 图号			REV. 版本
				ANGLES: ±1°	SHEET 1 OF 1 第 1 页 共 1 页		Approved: 核准	PART NO: 料号			01

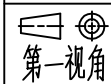

A4
SIZE

SCALE
比例
1:1

UNIT
单位
mm

CUSTOMER:
客户
MODEL NO:
料号

1

2

3

4